



control electronics

spido

Instructions and warnings for the fitter

Istruzioni ed avvertenze per l'installatore

Instructions et recommandations pour l'installateur

Anweisungen und Hinweised für den Installateur

Instrucciones y advertencias para el instalador

Instrukcje dla instalatora

COMPANY
WITH QUALITY SYSTEM
CERTIFIED BY DNV
== ISO 9001 ==



spido

table of contents

Indice:	page		page		
1	Product description	3	4	Programming	6
2	Installation	3	4.1	Programming pauses	6
2.1	Preliminary checks	3	4.2	Programming current sensitivity	7
2.2	Typical system layout	3	4.3	Programming the photo-test mode	7
2.3	Electrical connections	4	5	Testing	8
2.3.1	Electrical diagram	4	6	Maintenance	8
2.3.2	Description of connections	4	6.1	Disposal	8
2.3.3	Notes on connections	5	7	What to do if ...	8
2.3.4	Photo-test	5	8	Technical specifications	9
2.3.5	Checking connections	5	Annex:		
3	Programmable functions	5/6		SMXI radio receiver	10
3.1	Pre-set functions	6			

Warning:

⚠ This manual has been especially written for use by qualified fitters.

No information given in this manual can be considered as being of interest to end users!

This manual refers to the SP6000 gear motor and may not be used for different products!

The control unit has been designed to control electromechanical actuators for automated sectional and up-and-over doors; any other use is considered improper and is consequently forbidden by current laws. Do not install the unit before you have read all the instructions at least once!

1) Product description:

The control unit for the SP6000 is suitable for moving sectional doors, up-and-over doors with counterweights and up-and-over doors with springs; these are controlled by electromechanical actuators powered by 24 Vdc motors.

The board uses a system for controlling the force developed by the

motor; this is done by measuring the amount of current absorbed. This system recognises obstacles during normal movement (anti-crush safety feature). The level of current sensitivity can be set during the programming phase. To make it easier to recognise the various parts of the control unit, **Fig. 1a** shows the main components.

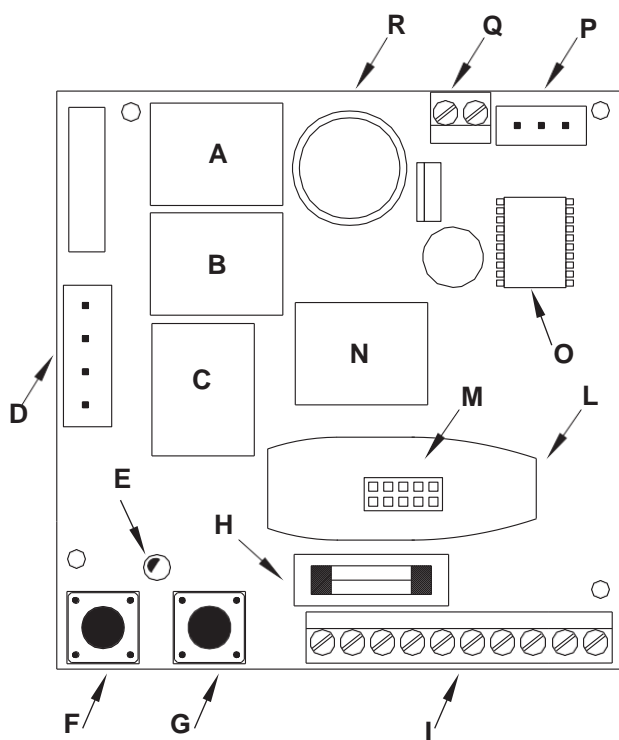

Description

- A Closing manoeuvre relay (CLOSE)
- B Opening manoeuvre relay (OPEN)
- C Speed change relay (FAST)
- D Transformer connector
- E OK Led
- F Programming button (PROG)
- G Step-by-step button (PP)
- H Low voltage rapid fuse (2A)
- I Input and output connection terminal board
- L Radio receiver box
- M Radio receiver connector
- N Flashing lamp/Photo-test output relay
- O Microcontroller
- P Travel stop connector
- Q Motor connection terminal board
- R Courtesy light

1a

2) Installation:

⚠ Automatic gate and door systems may only be installed by qualified fitters in the full respect of the law. Comply with the warnings shown in the "Warnings for fitters" chapter.

2.1) Preliminary checks

Before starting installation make sure that all the material is suitable for installation and complies with legal requirements. As well as checking all the points shown in the "Warnings for fitters", this section also contains a specific check list for the SP6000 gear motor.

- Check the strength and mechanical consistency of the door and make sure safety margins and minimum distances are respected.
- The power line must be protected by an overload cut-out switch and a residual current circuit breaker.
- Power the control unit using the plug provided with the product. Any extension cables used should be 3 x 1.5 mm².
- Use wires with a minimum cross section of 0.25 mm² to connect low voltage safety circuits. Use shielded wires if the length exceeds 30 m and connect the earth braid at the control unit end only.

2.2) Typical system layout

To clarify certain terms and aspects of a door automation system, we have included a typical example of a system for an up-and-over door.

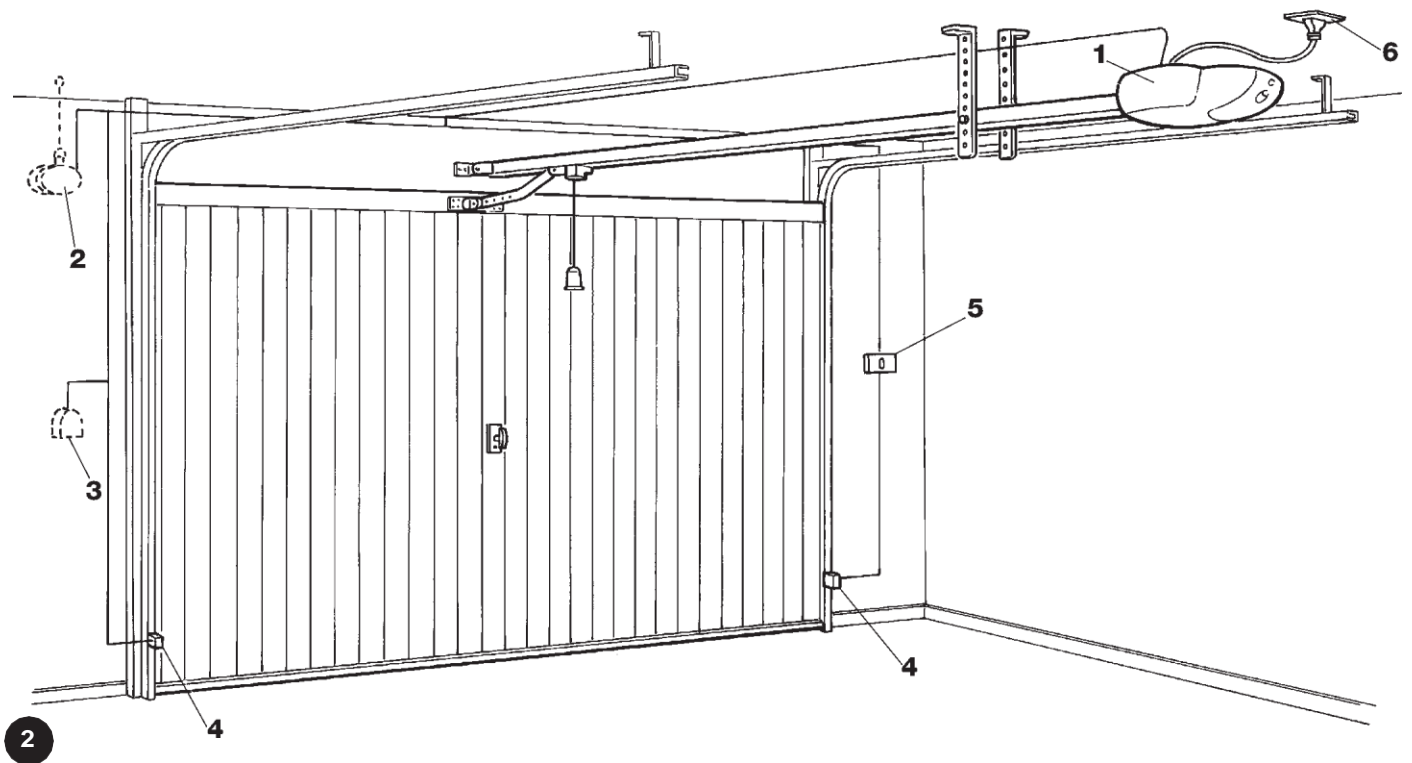

Description

The description refers to the typical system shown in **Fig. 2**

1. SP6000.
2. Flashing light with built-in aerial (installed outdoors).
3. Key or keypad switch (installed outdoors) to connect to the "Step-by-step" input.
4. Two photocells to connect to the "Photo" input.
5. Control buttons to connect to the "Step-by-step" or "Stop" input.
6. Power supply plug.

2.3) Electrical connections

⚠ To protect the fitter and avoid damaging the components while electrical connections are being made or the radio receiver is being connected, under no circumstances may the unit be electrically powered.

- If the inputs of the NC (Normally Closed) contacts are not used they should be jumped with the "24V Common" terminal (except for the photocell inputs; for information please see the "Photo-test" function).

- If there is more than one NC contact, they must be connected in "series".
- If the inputs of the NO (Normally Open) contacts are not used they should be left free.
- If there is more than one NO contact, they must be connected in "Parallel".
- The contacts must be mechanical and potential-free; no stage connections are allowed, such as those defined as "PNP", "NPN", "Open Collector", etc..

2.3.1) Electrical diagram

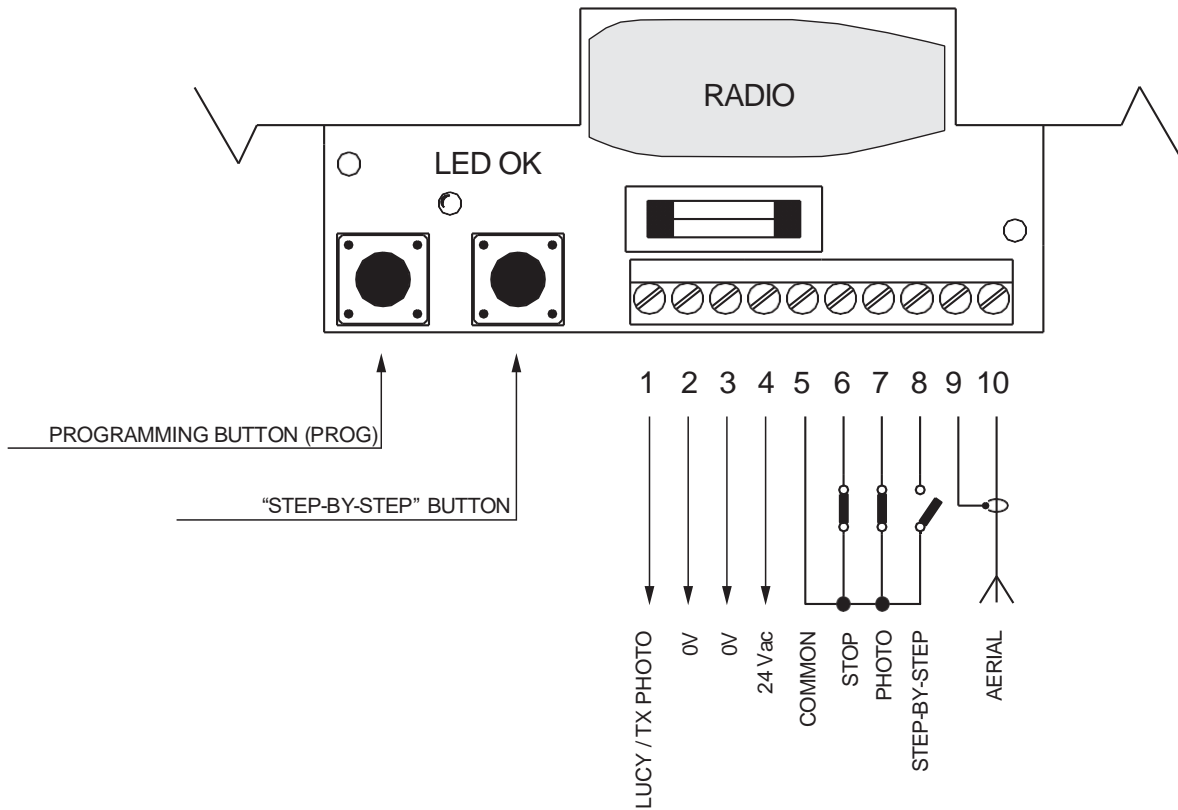

2.3.2) Description of connections

A brief description of the possible control unit output connections follows.

Terminals	Function	Description
1-2 :	LUCY/TX Photo	Auxiliary output (24Vac). The LUCY 24Vac flashing light (alternate current – maximum lamp power 25W) and the photocell transmitter if the “Photo-test” function is programmed can be connected to this output (see Figs. 6a-6b).
3-4 :	24Vac	24Vac output (alternate current) for powering services (Photocells, Radio, etc.) max. 200mA.
5-6:	Stop	Input with “Stop” function (emergency, shutdown or extreme safety). It is normally closed.
5-7:	Photo	Input for safety devices (photocells, pneumatic edges). It is normally closed.
5-8:	Step-by-step	Input for cycle function control (Open - Stop - Close – Stop”), the “Step-by-step” button (item G, Fig. 1a) activates this input.
9-10:	Aerial	Input for the optional radio receiver aerial.

2.3.3) Notes about connections

Most connections are extremely simple; many of them are direct connections to a single user point or contact.

The following figures show examples of how to connect external devices.

Figs. 5: Connecting the flashing light and photocells with “Photo-test” deactivated.

Figs. 6: Connecting the flashing light and photocells with “Photo-test” activated.

Figs. 7: Connecting the key switch.

Figs. 8: Connecting the external radio.
(Please refer to the drawings on the cover)

2.3.4) Photo-test

The control unit of the SP6000 features the "Photo-test" function. This is an excellent solution as regards the reliability of safety devices and puts the control unit + safety device assembly into "category 2" as per UNI EN 954-1 standard (ed. 12/1998). Whenever a manoeuvre is begun, the relative safety devices are checked and only if everything is in order will the manoeuvre start.

All this is only possible if a special configuration of the safety device connections is used; in practice, the "TX" photocell transmitters are powered separately from the "RX" receivers.

N.B.: when "Photo-test" is active, the photocell transmitter is only powered during the manoeuvre.

2.3.5) Checking connections

⚠ the next operations involve work being done on live circuits, some parts have mains voltage running through them and are therefore EXTREMELY DANGEROUS! Pay the greatest of attention to what you are doing and NEVER WORK ALONE!

After making connections, the whole system must be checked.

- Power the control unit and check that the OK Led flashes rapidly for a few seconds.
- Check that there is a voltage of 24Vac on terminals 3-4, 3-6, 3-7 and that there is a voltage of 0Vac on terminals 3-8; if this is not the case, unplug the unit immediately and carefully check the connections and the voltage input.
- After the initial rapid flashing, the OK Led shows the control unit is working correctly by flashing regularly at 1 second intervals. When there is a variation in the inputs, the OK Led flashes rapidly twice to show that the input has been recognised. When the photocells

detect an obstacle, the OK Led flashes rapidly twice, as it also does when the "Stop" input is deactivated.

- Carry out a test with the door disconnected from the motor; perform a brief opening and closing cycle and press the "Step-by-step" button to check the mechanical parts are in working order. (The first manoeuvre made after the unit is powered is always "Open"). At the end of the cycle, reconnect the door to the drive trolley.
- Then position the limit switch slides as shown in **Fig. 3**.

Press the "Step-by-step" button and check that the door moves in the opening direction. Press the step-by-step button when the door is 1 cm from the opening point, thereby stopping the manoeuvre; then insert the "Open" travel stop slide on the edge of the cover. Press the "Step-by-step" button again and check that the door moves in the closing direction. Press the "Step-by-step" button when the door is 1 cm from the closing point, thereby stopping the manoeuvre; then insert the "Close" travel stop slide on the edge of the cover.

3) Programmable functions:

The unit features two buttons used to programme various operating modes so as to make the system more suitable to user needs and safer in various conditions of use.

The control unit has two operating modes: semiautomatic and automatic.

"Semiautomatic" Mode:

In this mode, a command impulse on the "Step-by-step" input makes alternative opening and closing manoeuvres according to the "Open – Stop – Close – Stop" sequence.

"Automatic" Mode:

In this mode, after an open manoeuvre, a programmed pause takes place (by setting the pause time) after which the closing manoeuvre is carried out.

Current sensitivity:

The control unit features a system measuring the current absorbed by the motor and uses this to detect obstacles.

Given that the absorbed current depends on variable conditions (weight of door, various kinds of friction, gusts of wind, voltage variations, etc.) the cut-in threshold can be changed.

There are five levels: no. 1 is the lowest (minimum power), no. 5 is the highest (maximum power). Initially it is set at level 3, which should be the optimum one for most installations.

⚠ The "current sensitivity" function, suitably adjusted (together with other vital features) allows the system to comply with recent European standards, EN 12453 and EN 12445, which require techniques or devices to be used to limit force and danger when automatic gates and doors are moved.

3.1) Pre-set functions

The control unit of the SP6000 features some programmable functions. These functions can be changed at any time by carrying out a suitable (see chapter 3) that are initially pre-set in a typical configuration which programming procedure.

satisfies most automatic systems. These are:

- Mode : "semiautomatic"
- Photo-test : deactivated
- Current sensitivity : n° 3 average

4) Programming:

All the functions described in the "Programmable functions" chapter can be selected by means of a programming phase which terminates by memorising the choices made. The control unit therefore has a memory which stores the functions and parameters relative to the automation process.

Press "Step-by-step" and PROG on the board (see Fig. 4) to enter the programming mode.

The motor must not be running in this mode.

4.1) Programming pauses

This parameter allows the "automatic" or "semiautomatic" mode to be selected; the "pause", in fact, is the length of time the control unit waits after an opening manoeuvre before activating the automatic closing cycle.

To set the "automatic" mode, memorise the required "pause" ranging between 5 and 250 seconds. To set the "semiautomatic" mode, memorise a "pause" lasting less than 5 seconds.

Table "A1"	Activate the "semiautomatic" mode	Example
1.	Press and hold down the PROG button	
2.	Wait for the OK Led to remain permanently on	
3.	Release PROG before the courtesy light finishes flashing 5 times	

Table "A2"	Activate the "automatic" mode (pause between 5s and 250s)	Example
1.	Press and hold down the PROG button	
2.	Release PROG when the courtesy light has flashed the number of times equal to the required pause. The "pause" must be over 5 seconds, that is, 5 flashes	

4.2) Programming the amperometric level

Programming this parameter will allow you to select the amperometric level, i.e. the maximum power that the motor can develop.

You can program one of the five levels available: 1 = minimum, 2 = low, 3 = medium, 4 = high, 5 = maximum.

Table "A3"	Programming the amperometric level	Example
	The selected level corresponds to the number of flashes made by the courtesy light. One flash corresponds to level no. 1 (minimum) while five flashes correspond to level no. 5 (maximum)	
1.	Press and hold down the PROG key and wait for the courtesy light to start flashing	
2.	When the desired flashing occurs, press the PP key as well	
3.	Release the PP and PROG keys	

To check which level has been programmed: disconnect the power supply to the control unit; press and hold down the PROG key; reconnect the power supply and then release the PROG key. Count the number of flashes made by the courtesy light; they correspond to the amperometric level.

4.3) Programming the “Photo-test” mode

To activate the “Photo-test” mode, make the connections described in paragraph 2.3.3 “Notes on Connections” (see **Figs. 6a – 6b**), and not the connections shown in **Figs. 5a – 5b**).



Table “A4”	Activating “Photo-test”	Example
1.	Press and hold down the PROG button	
2.	When the OK Led remains permanently on; press STEP-BY-STEP; the courtesy light switches on	
3.	Release the PROG button	

Table “A5”	Deactivating “Photo-test”	Example
1.	Press and hold down the PROG button	
2.	When the OK Led remains permanently on, press STEP-BY-STEP; the courtesy light switches off	
3.	Release the PROG button	

Check whether the “Photo-test” mode is activated or deactivated: power the control unit and check how long the OK Led flashes,

- if it flashes rapidly for 2 seconds, “Photo-test” is deactivated;
- if it flashes rapidly for 4 seconds, “Photo-test” is activated.

5) Testing:

⚠The automation system must be tested by qualified and expert staff who must establish what tests to perform according to the relative risk.

Testing is the most important part of the whole installation phase. Each single component, e.g. motors, photocells and other safety devices, the radio receiver and the emergency stop can require a specific test phase; please follow the procedures shown in the respective instructions manuals.

To test the control unit, carry out the following procedure (the sequence refers to the control unit of the SP6000 with pre-set functions).

- After powering the control unit, check that the OK Led flashes at 1 second intervals. If this does not occur, turn power off immediately and check the fuse.
- Check that all the safety devices of the unit are in proper working order (emergency stop, photocells, pneumatic edges, etc.). Whenever a device cuts in, the OK Led flashes rapidly twice to signal that the event has been acquired.
- Now it is possible to carry out a complete cycle of the actuator. Press the “Step-by-step” button and check that the door stops automatically at the travel stop. Press the “Step-by-step” button again and check

that the door stops automatically at the opposite travel stop. Carry out several manoeuvres in order to evaluate any defects of installation or adjustment of the gear motor travel stops, as well as the presence of any friction points. While the closing manoeuvre is being performed, the board automatically memorises the time taken. After a complete cycle of manoeuvres (open and close touching both travel stops) the control unit decelerates movement during the final 3 seconds of the closing phase.

- Now check the safety devices cut in correctly. The ones connected to the “Photo” input have no effect during the opening manoeuvre but they will invert movement during the closing manoeuvre. The devices connected to the “Stop” input work during both the opening and closing manoeuvres and stop movement in each case.

In the closing manoeuvre, the control unit reduces speed and noise during the final phase. The point at which the reduction in speed takes place is automatically calculated according to the duration of the previous manoeuvres; for this reason it is necessary to carry out a few complete manoeuvres until the speed reduction point is established (at least ten manoeuvres should be carried out to establish the exact point in which speed reduces).

6) Maintenance:

As the control unit of the SP6000 is electronic, it needs no particular maintenance. Periodically check, however, at least twice a year, that the whole system is in perfect working order as indicated in the Testing chapter.

6.1) Disposal

This product is made from various types of material, some of which can be recycled (aluminium, plastic, electric wiring). Others must be disposed of (boards with electronic components).

Find out about recycling or disposal systems in compliance with current bylaws.

⚠ Some electronic components may contain polluting substances; do not dump them.

7) What to do if ...:

This section will help fitters to solve some of the most common problems that may arise during installation.

The OK Led doesn't light up.

- Check that the power cable is correctly fitted in the mains power socket.
- Check that there is 24Vac between terminals 3 and 4 of the terminal board.
- Check that the fuse is in working order. If it has blown, replace it with a 2A rapid fuse.

The manoeuvre does not start.

- Check that the "Stop" input is active, that is, voltage between terminals 3 and 6 on the terminal board is equal to approx. 24Vac. If voltage does not correspond, check that the connection to the "Stop" input is made with a device featuring a Normally Closed contact.
- Check that the photocells are connected to the "Photo" input as shown in **Figs. 5a – 5b** if the "Photo-test" is deactivated, or as shown in **Figs. 6a – 6b** if "Photo-test" is activated.
- Check that the voltage between terminals 3 and 7 is equal to 24Vac when the photocells cut in. If this is not the case, check the photocells work correctly by following the relative instructions.

The manoeuvre does not stop when the "Stop" input cuts in.

- Check if the connection to the "Stop" input is made with a normally closed contact, as indicated in the "Electrical diagram" in paragraph 2.3.1. If it is connected correctly, check that the OK Led flashes rapidly twice when the contact is opened.

The opening manoeuvre has begun but inverts immediately afterwards.

- The level of current sensitivity selected is too low to raise the door. Select a higher level of force as described in paragraph 4.2 "Programming current sensitivity".

When the manoeuvre begins, the courtesy light switches on but then it switches off immediately and the manoeuvre does not continue.

- The "Photo-test" mode is activated and the "Photo-test" was unsuccessful. Check that the photocells are connected as shown in **Figs. 6a – 6b**.
If the connection is correct, check the photocells work correctly by following the relative instructions.

The flashing light doesn't work.

- Check that voltage between terminals 1 and 2 is equal to about 24Vac during the manoeuvre. If the voltage corresponds, the problem is caused by the flashing light that must be checked by following the relative instructions.

8) Technical specifications:

Power input	SP6000	:	230Vac ±10% , 50 / 60Hz
	SP6000/V1	:	120Vac ±10% , 50 / 60Hz
Flashing light output		:	24 Vac (fixed voltage output), 25 W light bulb
Service supply output		:	24 Vac, maximum current 200 mA
Maximum duration of a manoeuvre		:	60 seconds.
Pause		:	Programmable from 5 to 250 seconds.
Courtesy light time		:	60 seconds.
Operating temperature		:	-20 °C - 70 °C

smxi radio receiver



Product description

The control unit of the SP6000 already features a radio receiver for “rolling code” transmitters belonging to the FLOR and VERY VR series produced by Nice. The special thing about this series is that the recognition code is different for each transmitter (it also changes every time it is used). Therefore, in order to allow the receiver to recognise a determined transmitter, the recognition code must be memorised. This operation must be repeated for each transmitter required to communicate with the control unit of the SP6000.

 *Up to a maximum of 256 transmitters can be memorised in the receiver. No one transmitter can be cancelled; all the codes must be deleted.*

During the transmitter code memorisation phase, one of these options may be chosen:

Type I. Each transmitter button activates the corresponding output in the receiver, that is, button 1 activates output 1, button 2 activates output 2, and so on. In this case there is a single memorisation phase for each transmitter; during this phase, it doesn't matter which button is pressed and just one memory sector is occupied.

Type II. Each transmitter button can be associated with a particular output in the receiver, e.g., button 1 activates output 3, button 2 activates output 1, and so on. In this case, the transmitter must be memorised, pressing the required button, for each output to activate. Naturally, each button can activate just one output while the same output can be activated by more than one button. One memory section is occupied for each button.

 *The control unit of the SP6000 only uses the first of the 4 receiver channels, in particular, output N°1 is connected to the “Step-by-step” output; outputs 2 – 3 – 4 are not used.*

Installing the aerial

The receiver requires an ABF or ABFKIT type aerial to work properly; 10 and the earth braid to terminal 9. If the aerial is installed in a place without an aerial the range is limited to just a few metres. The aerial that is not connected to earth (masonry structures), the braid's must be installed as high as possible; if there are metal or reinforced terminal can be earthed to provide a larger range of action. The earth concrete structures nearby you can install the aerial on top. If the point must, of course, be local and of good quality. If an ABF or cable supplied with the aerial is too short, use a coaxial cable with 50- Ohm impedance (e.g. low dispersion RG58); the cable must be no ABFKIT aerial cannot be installed, you can get quite good results longer than 10 m. Connect the central core of the cable to terminal using the length of wire supplied with the receiver as the aerial, laying it flat and connecting it to terminal 10.

Memorising a remote control

Warning: when the memorisation phase is activated, any transmitter correctly recognised within the reception range of the radio is memorised. Consider this aspect with care and remove the aerial if necessary to reduce the capacity of the receiver.

The procedures for memorising remote controls must be performed within a certain time limit; please make sure you read and understand the whole procedure before starting.

To carry out the following procedure, use the button on the radio receiver box (item A, Fig. 1b) and the respective Led (item B, Fig. 1b) to the left of the button.

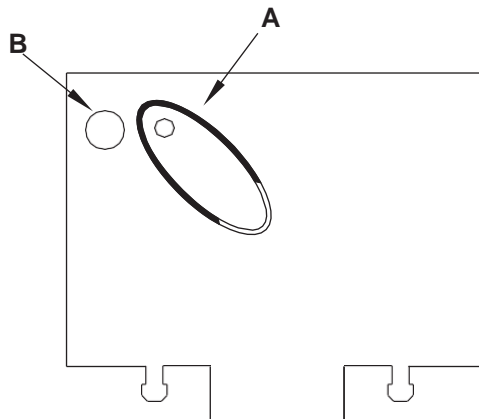

1b

Table "B1"	Memorisation mode I (each button activates the corresponding output in the receiver)	Example
1.	Press and hold down the receiver button for at least 3 seconds	3s
2.	Release the button when the Led lights up	
3.	Within 10 seconds, press button 1 of the transmitter to memorise for at least 2 seconds	2s
N.B.: If the procedure was memorised correctly, the Led on the receiver will flash 3 times. If there are other transmitters to memorise, repeat step 3 within another 10 seconds The memorisation phase finishes if no new codes are received for 10 seconds		x3

Table "B2"	Memorisation mode II (each button can be associated with a particular output)	Example
SP6000 can only use output n° 1. Do not use the other outputs, therefore		
1.	Press and release the button on the receiver	
2.	Check that the Led flashes	
3.	Memorise within 10 seconds by pressing the relative transmitter button for at least 2 seconds	2s
N.B.: If the procedure was memorised correctly, the Led on the receiver will flash 3 times. If there are other transmitters to memorise, repeat step 3 within another 10 seconds. The memorisation phase finishes if no new codes are received for 10 seconds.		x3







Remote memorising

It is possible to memorise a new transmitter in the receiver memory without using the keypad. A previously memorised and operational remote control must be available. The new transmitter will "inherit" the characteristics of the previously memorised one.

Therefore, if the first transmitter is memorised in mode **I**, the new one will also be memorised in mode **I** and any of the buttons of the transmitter can be pressed. If the first transmitter is memorised in mode **II** the new one will also be memorised in mode **II** but the button







activating the required output must be pressed on the first transmitter as must the button required to be memorised on the second.

Read all the instructions and then carry out the operations one after the other without interruptions. Now, with the two remote controls, NEW, the one whose code number we want to enter, and OLD, the previously memorised one, position yourself in the range of action of the radio controls (within their maximum range) and carry out the steps shown in the table.

Table "B3"	Remote memorising	Example
1.	Press the button on the NEW transmitter for at least 5 seconds	 x5s 
2.	Press the button on the OLD transmitter 3 times slowly	 1s  1s  1s
3.	Press the button on the NEW transmitter 1 time slowly and then release	 x1
N.B.: If there are other transmitters to memorise, repeat the above steps for each new transmitter		

Deleting all transmitters

All the memorised codes can be deleted as follows:

Table "B4"	Deleting all transmitters	Example
1.	Press the receiver button and hold it down	
2.	Wait for the Led to light up, then wait for it to switch off and then wait for it to flash 3 times	   x3
3.	Release the button exactly during the third flash	  3°
N.B.: if the procedure was performed correctly, the Led will flash 5 times after a few moments.		 x5

Technical characteristics of the system

GB

SMXI receiver

Reception frequency	:	433.92MHz
Input impedance	:	52ohms
Sensitivity	:	better than 0.5 mV (average range 150 – 200 m with aerial ABF-ABF KIT)
Decoding	:	52 bit rolling code (4.5 million billion combinations)
Working temperature	:	-10°C at +55°C

FLO2R transmitter

Radiated power	:	100μW, a 433.92MHz
Buttons	:	2
Power input	:	12 Vdc +20% -40% with 23A type battery
Average absorption	:	24mA
Working temperature	:	-40 °C ÷ +85 °C



COMPANY
WITH QUALITY SYSTEM
CERTIFIED BY DNV
==ISO 9001==

Nice SpA

Oderzo TV Italia

Via Pezza Alta, 13 Z.I. Rustigné

Tel. +39.0422.85.38.38

Fax +39.0422.85.35.85

info@niceforyou.com

Nice Belgium

Leuven (Heverlee) B

Tel. +32.(0)16.38.69.00

Fax +32.(0)16.38.69.01

nice.belgium@belgacom.net

Nice España Madrid E

Tel. +34.9.16.16.33.00

Fax +34.9.16.16.30.10

kamarautom@nexo.es

Nice France Buchelay F

Tel. +33.(0)1.30.33.95.95

Fax +33.(0)1.30.33.95.96

info@nicefrance.fr

Nice Polska Pruszków PL

Tel. +48.22.728.33.22

Fax +48.22.728.25.10

nice@nice.com.pl

www.niceforyou.com