

Sumo

Garage door opener

CE

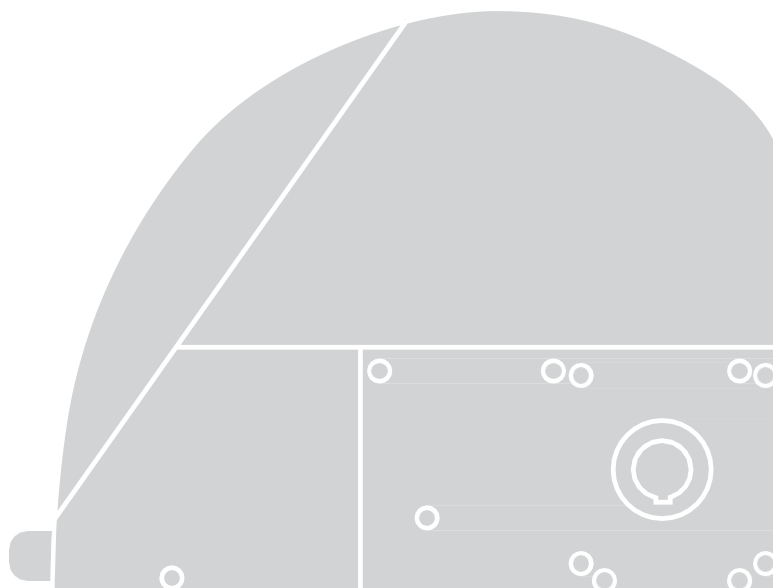

EN - Instructions and warnings for installation and use

IT - Istruzioni ed avvertenze per l'installazione e l'uso

FR - Instructions et avertissements pour l'installation et l'utilisation

ES - Instrucciones y advertencias para la instalación y el uso

DE - Installierungs-und Gebrauchsanleitungen und Hinweise

PL - Instrukcje i ostrzeżenia do instalacji i użytkowania

Nice

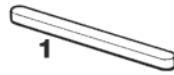
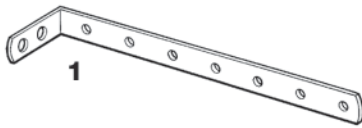
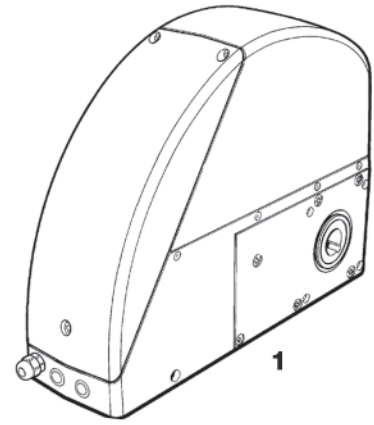
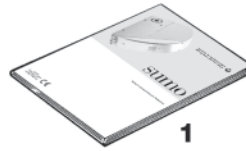
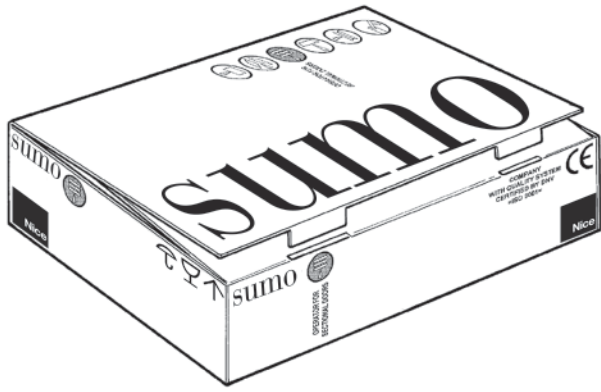

Versione SU2010



1



2



2



1



1



1

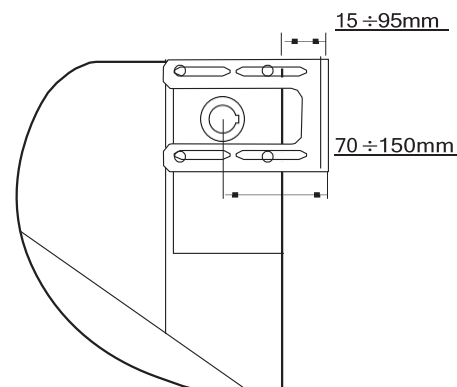
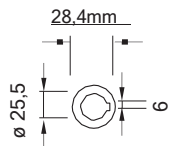
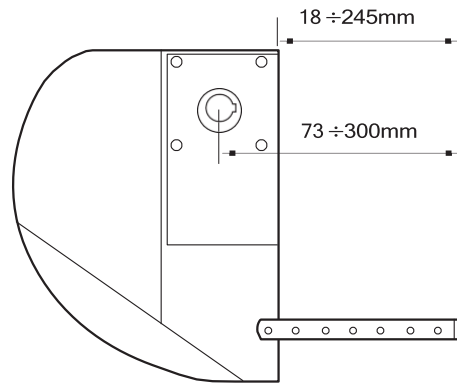
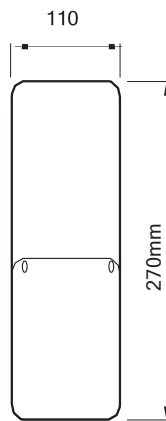
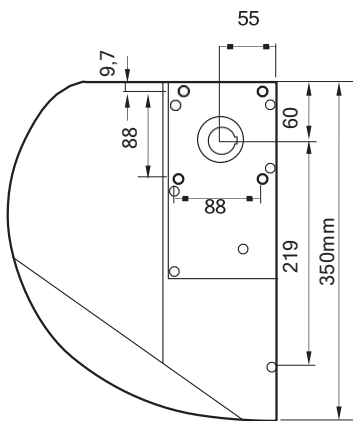

2

Sumo

Table of contents:

	page		page
1	Product description	4	Manual manoeuvre or release
2	Installation	5	Testing
2.1	Preliminary checks	6	Maintenance
2.2	Typical system layout	6.1	Disposal
2.3	Installing Sumo (standard procedure)	7	Technical specifications
2.4	Installing Sumo with vertical chain		Instructions and warnings for users of the SUMO gear motor
2.5	Installing Sumo with horizontal chain		
2.6	Electrical connections		
3	Installing the release device		

Important information

Congratulations on choosing this Nice product. Please read this handbook carefully.

To make these instructions easier to follow, we have, wherever possible, put them in the order in which they will be carried out during the various system installation phases. Please read these instructions and the attached "Warnings for fitters" file carefully before installing the product as they contain important information concerning safety, installation, use and maintenance.

Anything not expressly specified in these instructions is forbidden.

Operations not indicated in these instructions may cause damage to the product, people and property.

Nice declines all liability for badly built sectional doors or any deformations that may occur during use.

This product has been designed and produced for automating well-balanced doors that can be opened by hand; it must therefore be possible to completely open the door using a force of less than 300N (30kg) and stop it in any position; after it has been blocked it must neither rise or lower.

Do not install the product in explosive atmospheres.

1) Product description

SUMO is an electromechanical actuator for automating the movement of sectional doors and two-wing sliding doors (**fig. 3-11**). The cable outlet shaft makes it easy to connect the spring holder shaft to most of the sectional doors available on the market. As well as powering the direct current motor with encoder, the A924 control unit also offers precise torque and gear motor speed adjustment, exact position detection, gradual departure and closing, and obstacle detection. It also features a

maintenance LED which records the manoeuvres performed by the gear motor during its working life. The release device which disengages the motor from the gear motor can be activated from the ground.

2) Installation

2.1) Preliminary checks

Before proceeding with the installation of any powered system, check that the structure is suitable, that is, make sure it complies with current standards.

In particular, check that: the door does not stick when opening or closing; the door does not require a force of over 300N (30kg) to be moved; the door is well balanced, that is, if it stops in any position it remains motionless; the door moves silently, smoothly and doesn't skid;

the area identified for fitting the gear motor ensures the release manoeuvre can be made easily and safely; please remember that SUMO must power a door (sectional or two-wing) which must be in good condition and safe; it cannot make up for defects caused by incorrect installation or bad maintenance.

the packaging is undamaged, please see **fig. 1**; referring to **fig. 2**, check that the fixing area is compatible with the size of the gear motor.

Fig. 3 shows a typical installation of the gear motor.

2.2) Typical system layout

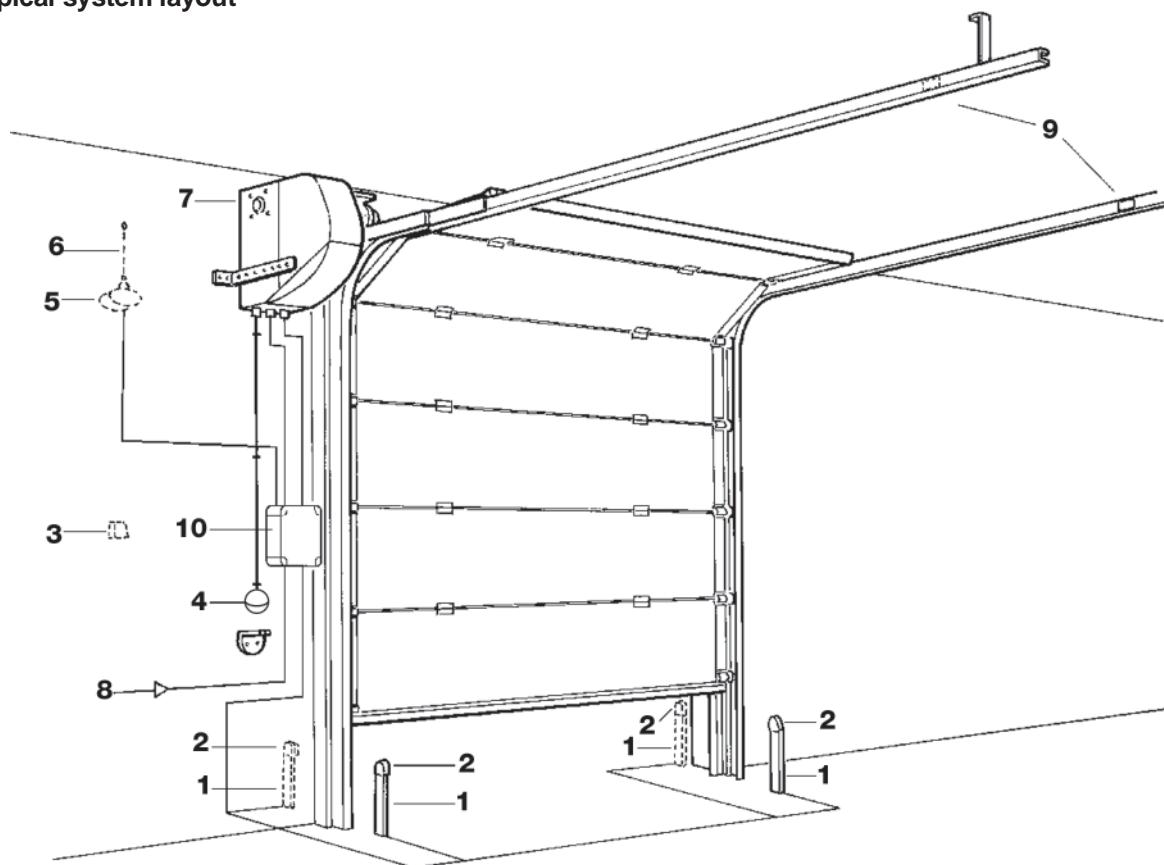

- | | | | |
|----|------------------------------|-----|-------------------------|
| 1. | Column | 6. | Aerial |
| 2. | Photocell | 7. | SUMO |
| 3. | Key switch or digital keypad | 8. | Power line |
| 4. | Release knob | 9. | Mechanical travel stops |
| 5. | Flashing light | 10. | A924 control unit |

2.3) Installing SUMO (standard procedure)*

1. Use a Phillips screwdriver to unscrew the 3 screws of the mobile cover and remove it (fig. 4).
2. Thread the wire through the cable holder (fig. 5).
3. Knock out the two aluminium plates and insert the two cable holders (21) (fig. 6).
- 4a. Lower the release lever with one hand (5).
- 4b. Block the lever with the bolt (14). (fig. 7).
5. After identifying on which side the gear motor must be installed, proceeding as indicated in the preliminary checks, insert SUMO in the spring holder shaft so that the two grooves coincide. Insert the tab (31) leaving it projecting from SUMO sufficiently far for it to be blocked with the clamp (not supplied) (fig. 8).
6. Rest the fixing bracket (41) against the wall and find the best hole for keeping SUMO parallel with the wall. Fix the bracket to SUMO with a screw (54) (fig. 9).
7. Drill holes in the wall over the holes of the bracket and fix it to the wall (for this operation, read the following fixing tips).
8. Hold the release lever with one hand, open the bolt and move it to the initial position.

* for the SU2010 version, please read chap. 3 "Installing the release device".

▲ Fixing tips (fig. 9a)

Fixing to steel:

If the bracket must be fixed to a steel bar use an M8 6.8 or M8 A2-50 bolt.

Fixing to concrete:

M8 HILTI HST-R-M8 expansion screw

h: 100mm (minimum wall thickness)

h1: 55mm (depth of hole)

Tinst: 25Nm (tightening torque)

hd: 9mm (depth of through hole)

Sw: 13mm (type of wrench)

If the wall is different from the above descriptions (masonry, wood, plastic, etc.), the fitter must choose the most suitable fixing method bearing in mind that the fixing system must withstand a traction force of 1000N (100kg).

2.4) Installing Sumo with vertical chain

Installation for special applications.

This installation system is required if:

- during the preliminary checks it was found that the size of the gear motor makes standard installation impossible
- during the preliminary checks it was found that the release manoeuvre could not be performed safely and easily;
- the level of transmitted torque is required to be increased with a further reduction. (Please consult the builder of the sectional door to discover if it has been designed to withstand the required torque).

NICE offers the following installation accessories:

CRA1 (shaft with pinion Z = 18)

CRA6 (gear Z = 36)

CRA7 (gear Z = 18)

CRA8 (wall-fixing bracket)

CRA2, CRA3, CRA4 (sufficient chain)

For a simple transmission of drive (Ratio 1:1) use: CRA1-CRA7

To reduce drive (Ratio 1:2) use: CRA1-CRA7

Please see fig. 10 for an example of installation.

- Keep the chain loose slack before fixing SUMO to the wall, otherwise after fixing the cable may be too taut.
- After fixing the brackets to the wall, the slots allow the position of SUMO to be adjusted in order to ensure the chain is fairly taut. Tighten the screws to complete fixing.
- Make that the pinion and the gear remain at the same level
- The chain must be at least 2.4m from the ground and always positioned so that it cannot be reached by people's arms; if this is not possible, protect it with a safety guard.

▲ Make sure that the shaft to which the gear must be splined is sufficiently rigid, that is, when subjected to a load of 4000N (400kg) it does not bend more than 2mm.

Otherwise, suitably strengthen it

2.5) Installing Sumo with horizontal chain

Installation on two-leaf sliding doors

Fig. 11 shows an installation example for driving two sliding wing.

NICE offers the following installation accessories:

CRA1 (shaft with pinion Z = 18)

CRA5 (chain tightening device)

CRA8 (wall-fixing bracket)

CRA2, CRA3, CRA4 (sufficient chain)

Please refer to the previous paragraph for installation instructions.

2.6) Electrical connections

⚠ The power unit must not be powered during this operation.

Thread the power cable and the encoder cable respectively through the central and the right-hand cable holders. Connect the three-pole power cable (3x2.5)* to terminals 1 – 2, keeping the earth wire insulated. Connect the two-wire cable (2x0.75) to terminals 3-4 (encoder).

Tighten the cable holder to prevent the cables from being torn from the terminal board. (Please consult **figs. 12-12a**) Close SUMO by screwing up the 3 screws of the cover with a Philips screwdriver.

*If the cable is longer than 10m, use a cross-section of 4mm.

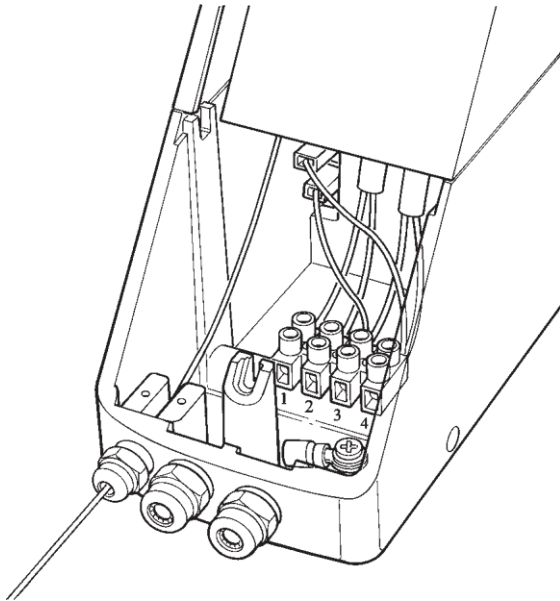

12

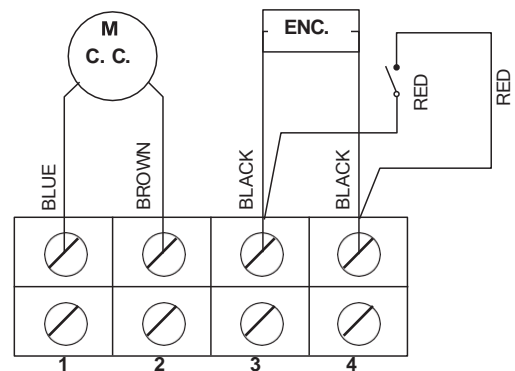

12a

3) Installing the release device

Installing the release device for model SU2000

Unwind the cord (max. L 6.5m) along the wall and thread it through any eyebolts (not supplied). At a distance of 80mm from the end of the cord, drill holes and fix the knob support bracket (42) for releasing from the ground to the wall (**Fig. 13**).

Installing the manual release device for model SU2010

Installation of the release system should be divided into two phases.

The first phase can be done on the ground while the second phase can be done after fitting the automated system.

Procedure:

Phase 1:

1. Remove a terminal cap from the sheath;
2. Use a Philips screwdriver to unscrew the 3 screws (47-48) of the cover (3) and remove it;
3. Lower the release lever (5) and block it with the bolt (14);
4. Unscrew the casing of PG7 (22) insert the end of the sheath without the cap as far as it can go
5. Insert the metal cable into the sheath from the cap side;
6. Tighten the sheath clamp (7) with the relative screws (46).

(**Fig. 14**).

7. Insert the steel cable into the slot furthest away from the release lever (5). Block the end of the cable with the relative fixing clamp making sure that it doesn't come out even when it is tugged hard (**Fig. 15**);

Phase 2:

1. Open the bolt (14) and move the release handle (5) to the initial position;
2. close the cover (3);
3. unwind the sheath (max. L 6.5m) along the wall making sure to keep it straight so that the metal cable can slide easily inside the sheath;
4. insert the clamp (69) into the metal cable;
5. connect the release knob (43) to the metal cable, remove any excess if necessary;
6. adjust the fixing height of the clamp and release (**fig. 16a**).
Adjust the position of the clamp if necessary until SUMO is released when the knob is moved to position 1.

4) Manual manoeuvre or release

Models SU2000 – SU2010

Pull the knob downwards to position 1.
Move the door by hand. (Figs. 16 - 16a)

The release device must only work when the door is stopped.
To programme and adjust anti-squash torque, please see the instructions of the A924 control unit.

5) Testing

The whole system must be tested by qualified and expert staff who must perform the tests required, according to the level of risk.

To test SUMO, proceed as follows:

- close the door;
- disconnect the power supply from the control unit;
- release the gear motor;
- check that the slide way is clean and free from debris;
- completely open the door manually making sure to exercise a force always less than 300N (30kg);
- check that the door does not stick when moving;
- check that when the sectional door is stopped at any point it remains motionless;
- check that the safety system and mechanical stops are in good condition;
- check that the screw connections are perfectly tight;
- check, where present, that the chain is taut and that it slides well, lubricate if necessary.
- after the above checks, block the gear motor and power the control unit.
- adjust (from the electronic control unit) the force of the actuator so that it can move just the door;
- measure the force of impact as required by EN12445 and EN1245353 standards.

6) Maintenance

The A924 control unit features a maintenance LED (see the instructions handbook for the A924 electrical power unit for further information). This signals when routine maintenance operations are required. Not only does regular maintenance offer longer life, but also correct and safe system operation.

Maintenance may only be performed by qualified staff.
Maintenance involves repeating the test procedure.

6.1) Disposal

SUMO comprises various types of materials which must be disposed of in compliance with the laws of the country of installation.

There are no particular dangers or risks deriving from demolition of the system.
If waste sorting is required, the components should be grouped by type of material (electrical, aluminium, plastic, etc.).

7) Technical specifications

SUMO 2000 - 2000V - 2000VV

Irreversible 24Vdc gear motor with encoder and local and cable release devices.

SUMO 2010

Irreversible 24Vdc gear motor with encoder, local and cable release devices and sheath.

		SU2000	SU2010	SU2000V	SU2000VV
Power input	(Vdc)	15 ÷ 36			
Motor absorption	(Adc)	13			
Absorbed power	(W)	500			
Protection level	(IP)	44	54	44	
Torque	(Nm)	120		82	46
Speed	(rpm)	7.5 ÷ 16 (6)*		11 ÷ 23.5 (9)*	19.5 ÷ 42 (15)*
Max. surface of door	(m2)	35		25	15
Operating temp.	(°C Min/Max)	-20°÷50°			
Insulation class		B			
Work cycles	(%)	50			
Weight	(kg)	10.5			
Hole	(mm)	25.5			

* The value in brackets refers to the deceleration phase of the A924 control unit.



Sumo

Instructions and warnings for users of the SUMO gear motor

Congratulations on choosing a Nice product for your automation system!

Nice S.p.A. produces components for automating gates, doors, shutters and awnings: gear motors, control units, radio control units, flashing lights, photocells and accessories.

Nice only uses first rate materials and production processes and constantly develops innovative technical, aesthetic and ergonomic solutions in order to make its products as simple to use as possible: your fitter will certainly have chosen the most suitable article for your requirements from the large range of Nice products.

Nice however, is not the producer of your automated system as this is the result of a process of analysis, evaluation, choice of materials and installation performed by your fitter.

Each automated system is unique and only your fitter has the experience and professionalism required to create a system that is tailor-made to your requirements, featuring long-term safety and reliability, and, above all, professionally installed and compliant with current regulations.

An automated system is handy to have as well as being a valid security system. Just a few, simple operations are required to ensure it lasts for years.

Even if your automated system satisfies regulatory safety levels, this does not eliminate "residue risks", that is, the possibility of dangerous situations being generated, usually due to irresponsible or incorrect use. For this reason we would like to give you some suggestions on how to avoid these risks:

- **Before using your automated system for the first time**, ask your fitter to explain how residue risks can arise and spend a few minutes reading the **instructions and warnings** for the user handbook that the fitter will have given you. Keep this manual for future use and, if you should ever sell your automated system, hand it over to the new owner.
- **Your automated system is a machine which carries out your commands to the letter**; irresponsible or incorrect use may cause it to become dangerous: do not move the automated system if animals or objects are in its working radius.

- **Children:** an automated system ensures a high level of safety as it always offers reliable and safe operation and its detection systems stop it from moving in the presence of people or objects. However, children should not be allowed to play near it. Do not let them accidentally use the system by leaving the remote control unit within their reach: **it is not a toy!**
- **Faults.** If you notice any abnormal behaviour, disconnect the system from the electricity supply immediately and perform the manual release operation. Do not attempt to make repairs yourself but call in your fitter: in the meantime the system can work as a non-automated gate once the gear motor has been released as described further on.
- **Maintenance.** Just like all machines, your automated system requires periodic maintenance to ensure it works as long as possible and in total safety. Agree on a routine maintenance plan with your fitter; Nice recommends a visit once every six months for normal residential use but this period can vary depending on how often the system is used. All controls, maintenance work or repairs may only be carried out by qualified personnel.
- Do not modify the system or its programming and adjustment parameters even if you think you can do it: your fitter is responsible for this.

- Final testing, routine maintenance and any repairs must be documented by the fitter and such documents kept by the owner of the system.
- **Disposal.** At the end of the life of the automatic system, make sure that it is demolished by qualified personnel and that the materials are recycled or disposed of according to local regulations.
- **In case of breakage** or during a power failure. While waiting for your fitter to call (or power to come on again if the system does not have buffer batteries), the system can be used just like any other manual opening system. To do this, perform the manual release operation: this can be done by the user and Nice has made it as easy as possible, without the need for tools or physical effort.

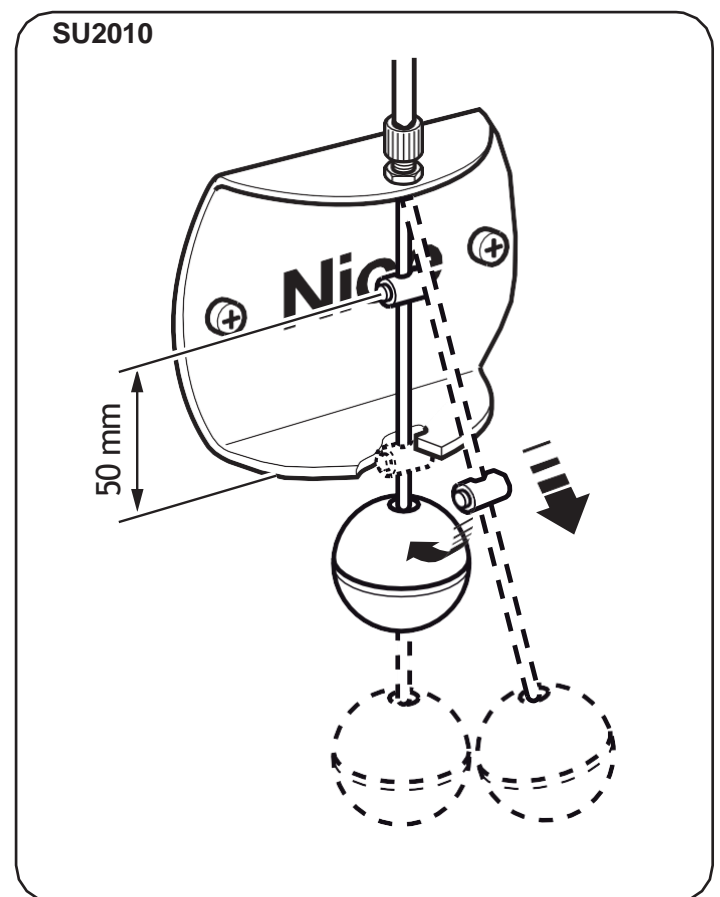
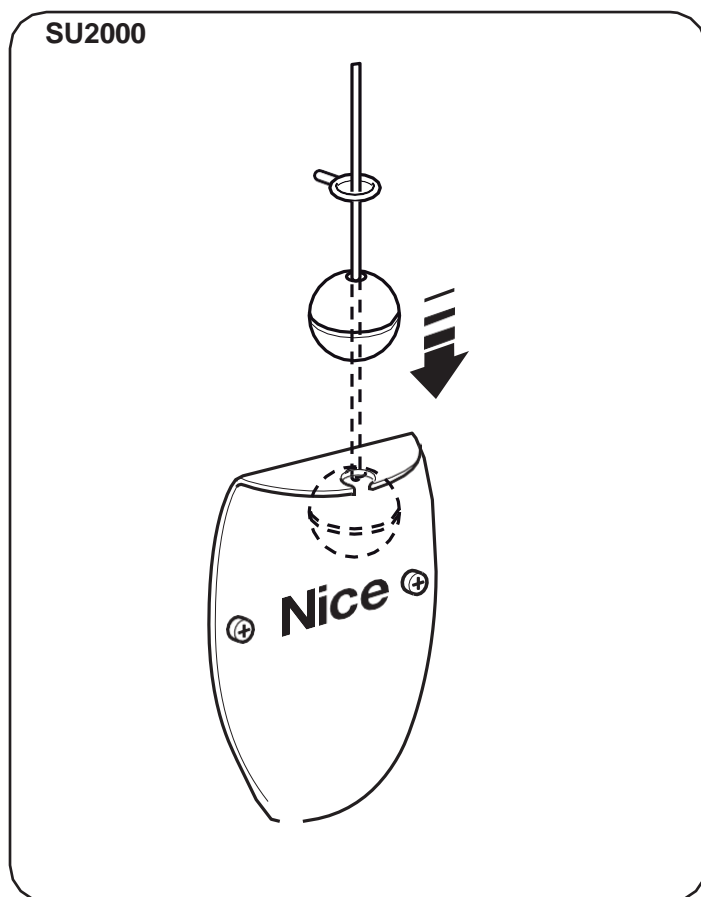

1. Pull the knob downwards to position 1.
2. Move the door by hand.

⚠ The release device must only work when the door is stopped.

Important: if the radio control unit (if supplied) starts working badly after a time, or does not work at all, the batteries may be flat (They can last from several months to two/three years depending on the type). You can notice this from the fact that the transmission OK LED is faint, doesn't light up at all, or lights up for just a moment. Before contacting your fitter, try exchanging the battery with that of another transmitter you know that works: if this is the reason for the fault, just replace the battery with another one of the same kind.

Are you satisfied? If you wish to add a new automated system to your house, contact your fitter and we at Nice will provide the advice of a specialist, the most developed products on the market, leading-edge operativeness and maximum compatibility.

Thank you for reading these suggestions and we trust you are fully satisfied with your new system: please contact your fitter for all your current or future requirements.

